

## 1.1 SCOPE OF MANUAL

This manual contains a description, installation and operating instructions, and maintenance instructions for the Plug-In Discriminator Module. To support any maintenance that might be required, a description of the theory of operation is also included, and a list of replaceable parts is given. A list of recommended spares is also included.

## 1.2 PURPOSE OF EQUIPMENT

The Amplitude Discriminator Module (ADM) is available in two input configurations. In one, the unit produces a DC output proportional to the highest of up to four DC inputs. When used in this fashion, the unit is a "high" selector. The other input arrangement causes the output to be proportional to the lowest input, thus making the unit a "low" selector.

## 1.3 GENERAL DESCRIPTION

With the input circuit of the unit in the "high-selector" configuration, the DC input signals are applied to solid-state elements that are arranged to pass the signal of highest amplitude to the amplifying stages. In the "low-selector" configuration, the unit employs an additional integrated circuit that, with the other circuit elements, is arranged to pass the signal of lowest amplitude to the amplifying stages. Amplification is accomplished by an operational amplifier and a power amplifier. A large amount of feedback is used to achieve high stability of performance. The output circuit can be arranged to produce either current or voltage output.

## 1.4 SPECIFICATIONS

The specifications of the ADM are given in Table 1-1.

TABLE 1-1. ADM SPECIFICATIONS

INPUTCURRENT

1-5 mA into 100 ohms  
4-20 mA into 250 ohms  
10-50 mA into 100 ohms

VOLTAGE

0-5V, 1-5V standard. 1 megohm minimum input impedance. Other voltages optional

INPUT NUMBER

2, 3, or 4 intermixed type, current or voltage.

TABLE I-1. ADM SPECIFICATIONS (Cont'd)

<u>FRONT PANEL ADJUSTMENTS</u>	Adjustable with multiturn potentiometer
<u>SPAN</u>	With full scale input, adjusts output to 100% $\pm$ 20 of selected output span
<u>ZERO</u>	With minimum input, adjusts output to 0% $\pm$ 10% of selected output span
<u>OUTPUT</u>	Operational amplifier feedback current source; output limited to 150% of maximum output range value
<u>CURRENT</u>	1-5 mA into 0-6000 ohm load 4-20 mA into 0-1500 ohm load 10-50 mA into 0-600 ohm load
<u>VOLTAGE</u>	1-5 VDC standard at 20 mA DC maximum
<u>RIPPLE</u>	10 mV P/P at maximum span and maximum load resistance
<u>LOAD EFFECT</u>	$\pm$ 0.01% of span from 0 to maximum load resistance (current output)
<u>PERFORMANCE</u>	
<u>CALIBRATION CAPABILITY</u>	$\pm$ 0.25% of span (linearity and repeatability)
<u>AMBIENT TEMPERATURE RANGE:</u>	-20 $^{\circ}$ F to +180 $^{\circ}$ F (-29 $^{\circ}$ C to +82 $^{\circ}$ C)
<u>AMBIENT TEMPERATURE EFFECT:</u>	$\pm$ 0.01% of span/ $^{\circ}$ F over above range
<u>FREQUENCY RESPONSE</u>	50 Hz (3-dB point)
<u>ISOLATION</u>	Voltage output units have input negative side common to output negative side. Current output models have output negative side elevated above input negative side (true current source). Mixed outputs are optionally available. Power input isolation is maintained on both AC and DC powered units
<u>POWER INPUT</u>	24 VDC, 45 VDC, 65 VDC $\pm$ 10% 5 watts maximum
<u>LINE VOLTAGE EFFECT</u>	$\pm$ 0.005%/1% line change

1.5 MODEL NUMBERING SYSTEM

Model Numbers describe an instrument's type, functional range, and features. If all accompanying documentation of a unit should be missing, one can still "translate" the Model Number back into a working description of the unit by using the information in this paragraph as a reference. The model number may be found on a label attached to the plastic handle.

BASIC EXAMPLE:

ADM/3X4-20MA/1-5V/24DC/-LD

ADM, three 4-20 mA inputs,  
1-5V output, 24 VDC power

BASIC INSTRUMENT TYPE:

ADM indicates Amplitude  
Discriminator Module

INPUT RANGE:

Numbers indicate minimum and  
maximum output range. High Signal  
Select is standard.

OUTPUT RANGE:

Numbers: Minimum and maximum  
nominal output range

POWER INPUT:

DC power, 24 VDC  $\pm 10\%$  unless stated  
otherwise, e.g., 45 VDC, 65 VDC

OPTIONS:

-LD Low Signal Select Option  
(no option call-out indi-  
cated "HIGH SELECT")

TABLE 1-2. ADM OPTIONS

-LD	Low Signal Select Option
-RO	Reversed Output Option
-FU	Power Fuse Option

## INSTALLATION INFORMATION

## 2.1 GENERAL INSTALLATION INFORMATION

Installation, in general, consists of calibration (when required), mechanical mounting, and making the electrical connections to the unit. The following paragraphs describe the necessary procedures.

## 2.2 CALIBRATION

Units are calibrated and checked for proper performance at the factory before they are shipped. However, unless calibration was requested to a specific set of input-output values, the unit should be calibrated by the user before the unit is placed in service.

NOTE

Adjustments should not be made in the field on units that are calibrated to values specified in the purchase order. Units that are calibrated at the factory to customer's specifications have protective caps over the SPAN and ZERO potentiometers; do NOT remove these caps.

Two adjustable input signal sources and input monitoring devices and an output monitoring device are required for calibration. The monitoring devices (current or voltage) must have an accuracy within 0.05% or better.

NOTE

Refer to paragraph 1.5 for information on how to use the model number to determine the number of inputs to be applied to the unit and to obtain the specified values of minimum and maximum inputs and outputs

Because the unit is available in either of two different input configurations, ("high-selector" and "low selector"), the specific calibration procedure to be followed will depend on the particular configuration of the unit being calibrated. The procedures are described in the following two paragraphs; use the one applicable to the unit being calibrated.

2.2.1 Calibration Of Unit With "High-Selector" Configuration

To calibrate a unit with "high-selector" configuration, proceed as follows:

- a. Connect one input signal source to the SI (1)\* and -S(2)\* terminals of the unit and the other test equipment as shown in Figure 2-1. Do not connect the second signal source to the unit at this time.

## INSTALLATION INFORMATION

- m. Repeat steps (j) through (l) for all pairs of inputs. The output should linearly follow the higher of the two inputs with the difference between the two inputs no greater than 0.25% of their initial value (minimum input plus 50% of the span).
- n. After step (m) has been successfully completed, remove the input signals and then turn off the power input to the unit.

### 2.2.2 Calibration Of Unit With "Low-Selector" Configuration

Table 2-1 lists some of the ranges of inputs that may be applied to the different terminals of the unit, the terminal being tested, the current-signal terminals to be connected together, and the current to be applied to these terminals from the second signal source. Refer to this table as directed in the following procedure. To calibrate a unit with "low-selector" (-LD option) configuration, proceed as follows:

- a. Connect one input signal source to the SI (1)\* and -S (2)\* terminals of the unit and the other test equipment as shown in Figure 2-1. Connect the second signal source to the terminals indicated in Table 2-1.
- b. Make sure both input signal sources are adjusted for zero output. Apply power to the unit.
- c. Refer to Table 2-1 and adjust the second signal source to apply the indicated signal to the terminals listed, with SI as the test terminal.
- d. Adjust the SI input signal source to the value of the minimum SI input signal that will be applied to the unit (1 mA, 4 mA, 10 mA, 1 VDC, or whatever the minimum SI input signal will be).
- e. Adjust the ZERO potentiometer to obtain 0% output (1 mA, 4 mA, 10 mA, 1 VDC, or whatever the 0% output will be) with the inputs applied as in steps (c) and (d).
- f. Adjust the SI signal source to the value of the maximum SI input signal that will be applied to the unit (5 mA, 20 mA, 50 mA, 5 VDC, or whatever the maximum SI input signal will be).
- g. Adjust the SPAN potentiometer to obtain 100% output with the inputs applied as in steps (c) and (f).

\* Indicates P.C. connector and terminal block number located on card rack.

## INSTALLATION INFORMATION

- b. Make sure all input signal sources are adjusted for zero output. Apply power input to the unit.
- c. Adjust the SI input signal source to the value of the minimum SI input signal that will be applied to the unit (1 mA, 4 mA, 10 mA, 1 VDC, or whatever the minimum SI input signal will be). Ground all other inputs.
- d. Adjust the ZERO potentiometer to obtain 0% output (1 mA, 4 mA, 10 mA, 1 VDC, or whatever the 0% output will be) with the minimum input applied as in step (c).
- e. Adjust the input source to the value of the maximum SI input signal that will be applied to the unit (5 mA, 20 mA, 50 mA, 5 VDC, or whatever the maximum SI input signal will be).
- f. Adjust the SPAN potentiometer to obtain 100% output with the maximum input applied as in step (e).
- g. Repeat steps (c) through (f) until no further adjustment of either the ZERO or SPAN potentiometer is required.
- h. Apply minimum input plus 25%, 50%, and 75% of the span and check that the output is linearly proportional (within  $\pm 0.25\%$ ).
- i. Reduce the input at SI to 0. Perform step (h) with input applied to S2 (3)\*, S3 (10)\* and S4 (13)\* successively (as required) and with the unused input terminals grounded.
- j. Connect one input signal source to SI on the unit and the second signal source to another input terminal. Adjust the input signal sources to minimum signal plus 50% of the span for each terminal. Check that the output is 50%.
- k. Slowly increase the input to SI. Note the amount of increase required for the output to follow the input. The increase should not exceed 0.25% of the initial value and the output should follow linearly. Return the SI input to its initial value in step (j).
- l. Repeat step (k) except increase the input to the other terminal of the unit while holding the input to SI constant. The result should be as described in step (k). Return the increased input to its initial value in step (j).

\* Numbers in paragraph indicate P.C. connector and terminal block numbers located on card rack.



## INSTALLATION INFORMATION

- h. Repeat steps (e) and (g) until no further adjustment of either the ZERO or SPAN potentiometer is required.
- i. Apply the minimum input plus 75%, 50%, and 25% of the span and check that the output decreases linearly (within  $\pm 0.25\%$ ) as the input signal is decreased.
- j. Perform step (i) with the variable input applied to S2, (3)\*S3, (10)\* and S4 (13)\* successively (as required) and with other terminals connected together and driven by the second signal source or left open as indicated in Table 2-1 for each test.
- k. Connect one input signal source to S1 on the unit, and the other input signal source to the input terminals that are connected together, as indicated in Table 2-1. Adjust the input signal connected to S1 to the minimum signal plus 50% of the span. Adjust the other input signal to the value indicated in Table 2-1 for step (k).
- l. Slowly decrease the input to S1. Note the amount of decrease required for the output to decrease and follow the input. The decrease in input should not exceed 0.25% of the initial value and the output should follow (decrease) linearly. Return the S1 input to its initial value in step (k).
- m. Repeat steps (k) through (l) for all pairs of inputs, referring to Table 2-1 to obtain the value to which the second signal source should be adjusted. The results should be as described in step (l). Return the decreased input to its initial value in step (k) after each test.
- n. After step (m) has been successfully completed, remove the input signals and then turn off the power input to the unit.

\* Indicates P.C. connector and terminal block numbers located on card rack

## INSTALLATION INFORMATION

TABLE 2-1. INPUT TERMINAL CONNECTIONS FOR CALIBRATION OF "LOW-SELECTOR" UNIT

INPUT SIGNAL RANGE				TEST TERMINAL	TERMINALS CONNECTED TOGETHER	SIGNAL FROM SECOND SOURCE APPLIED TO TERMINALS CONNECTED TOGETHER	
TERMINALS						(c)	(k)
(S1(1))*	S2(3)*	S3(10)*	S4(13)*				
1-5mA	1-5mA	1-5mA	1-5mA	S1	S2, S3, S4	15mA	9mA
				S2	S1, S3, S4	15mA	9mA
				S3	S1, S2, S4	15mA	9mA
				S4	S1, S2, S3	15mA	9mA
4-20mA	1-5mA	1-5mA	1-5mA	S1	S2, S3, S4	15mA	9mA
				S2	S1, S3, S4	30mA	18mA
				S3	S1, S2, S4	30mA	18mA
				S4	S1, S2, S3	30mA	18mA
10-50mA	1-5mA	1-5mA	1-5mA	S1	S2, S3, S4	15mA	9mA
				S2	S1, S3, S4	60mA	36mA
				S3	S1, S2, S4	60mA	36mA
				S4	S1, S2, S3	60mA	36mA
1-5mA	1-5mA	1-5mA	1-5VDC	S1	S2, S3, S4	10mA	6mA
				S2	S1, S3, S4	10mA	6mA
				S3	S1, S2, S4	10mA	6mA
				S4	S1, S2, S3	15mA	9mA
1-5mA	4-20mA	10-50mA	1-5VDC	S1	S2, S3, S4	70mA	52mA
				S2	S1, S3, S4	55mA	33mA
				S3	S1, S2, S4	25mA	15mA
				S4	S1, S2, S3	75mA	45mA
1-5VDC	1-5VDC	1-5VDC	1-5VDC	S1	S, S3, S4	3.0VDC FOR STEP (k) 5 VDC FOR STEP (c)	
				S2	S1, S3, S4		
				S3	S1, S2, S4		
				S4	S1, S2, S3		
				S1, S2	S3, S4		
				S1, S3	S2, S4		
				S1, S4	S2, S3		
				S2, S3	S1, S4		
				S2, S4	S1, S3		
				S3, S4	S1, S2		

\* Indicates connector and terminal number located on card rack.

### 2.3 MECHANICAL INSTALLATION

Figure 2-2 shows the outline dimensions and other installation requirements for the plug-in ADM. Be sure to observe the applicable special procedures and precautions given with the illustration. Be sure that the card rack has adequate ventilation.

### 2.4 ELECTRICAL CONNECTIONS

The electrical connections are made to terminals on the mating connector for the unit. The terminals to be used for the electrical connections are indicated in Figure 2-3. The following paragraphs provide additional information on wiring the unit.

#### 2.4.1 General Wiring Techniques

No special wire or cable is required for signal connections to the unit. To avoid transients and stray pickup, it is recommended that twisted conductors be used where they are run close to other services (such as power wiring). Spade-lug connectors are recommended for all wire terminations. All terminals on card racks are supplied with 6-32 screws long enough to easily accept three spade-lug connectors.

#### 2.4.2 Power Connections

The DC (9)\* P.C. connector pin is connected to the + (positive) side of the source, and the DCC (8)\* P.C. connector pin is connected to the - (negative) side. When the ADM is used in a M.I.I. card rack, the DC power source is connected to the power terminal block on the card rack. The DC source should be regulated to within  $\pm 10\%$  of the nominal voltage and should be capable of delivering 5 watts.

\* Indicates P.C. connector pin on unit.

DC MILLIAMMETER, USED ONLY FOR CURRENT INPUT (SEE NOTE 1)

USE OUTPUT MONITORING DEVICE CORRESPONDING TO RATED OUTPUT (SEE NOTE)

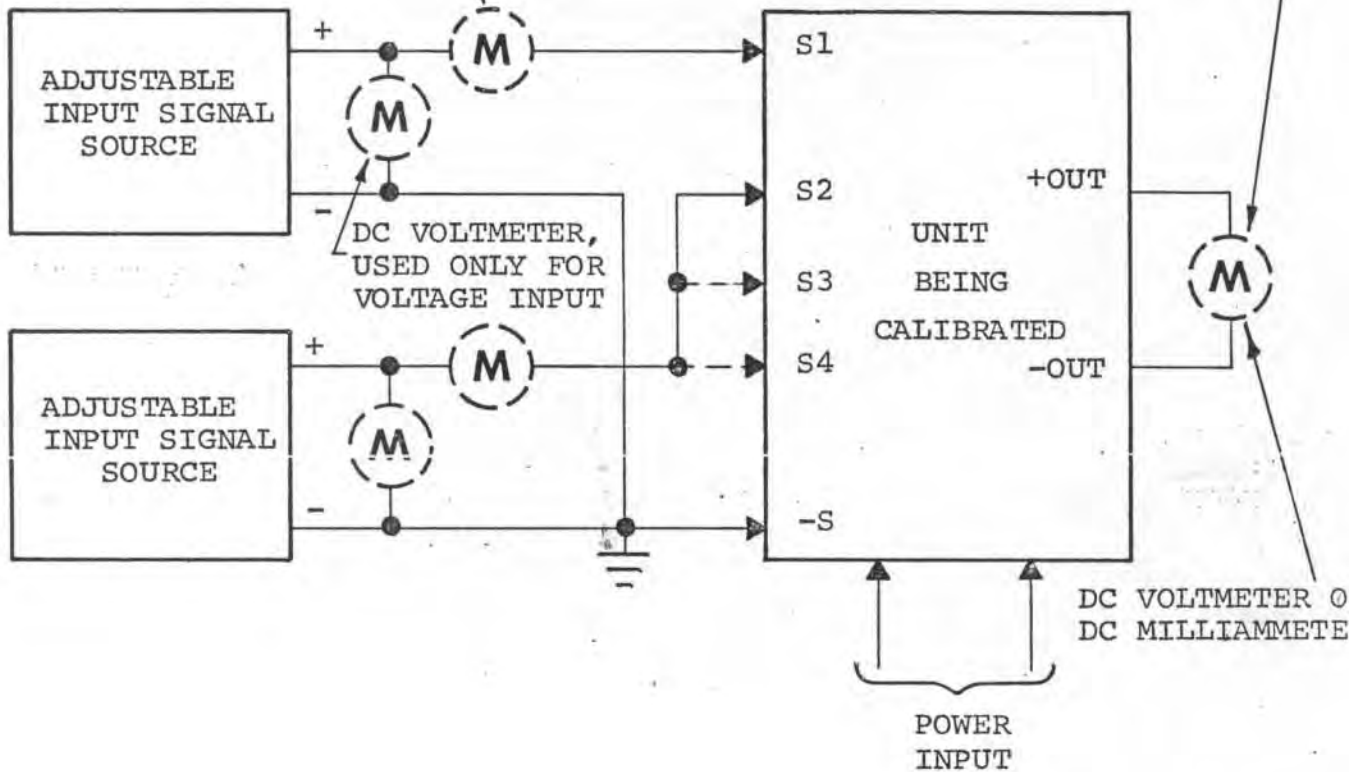

NOTE :

1. INPUT AND OUTPUT MONITORING DEVICES MUST BE ACCURATE TO WITHIN  $\pm 0.05\%$  OR BETTER.

Figure 2-1. Test Equipment Setup For Calibration Of Unit

## INSTALLATION INFORMATION

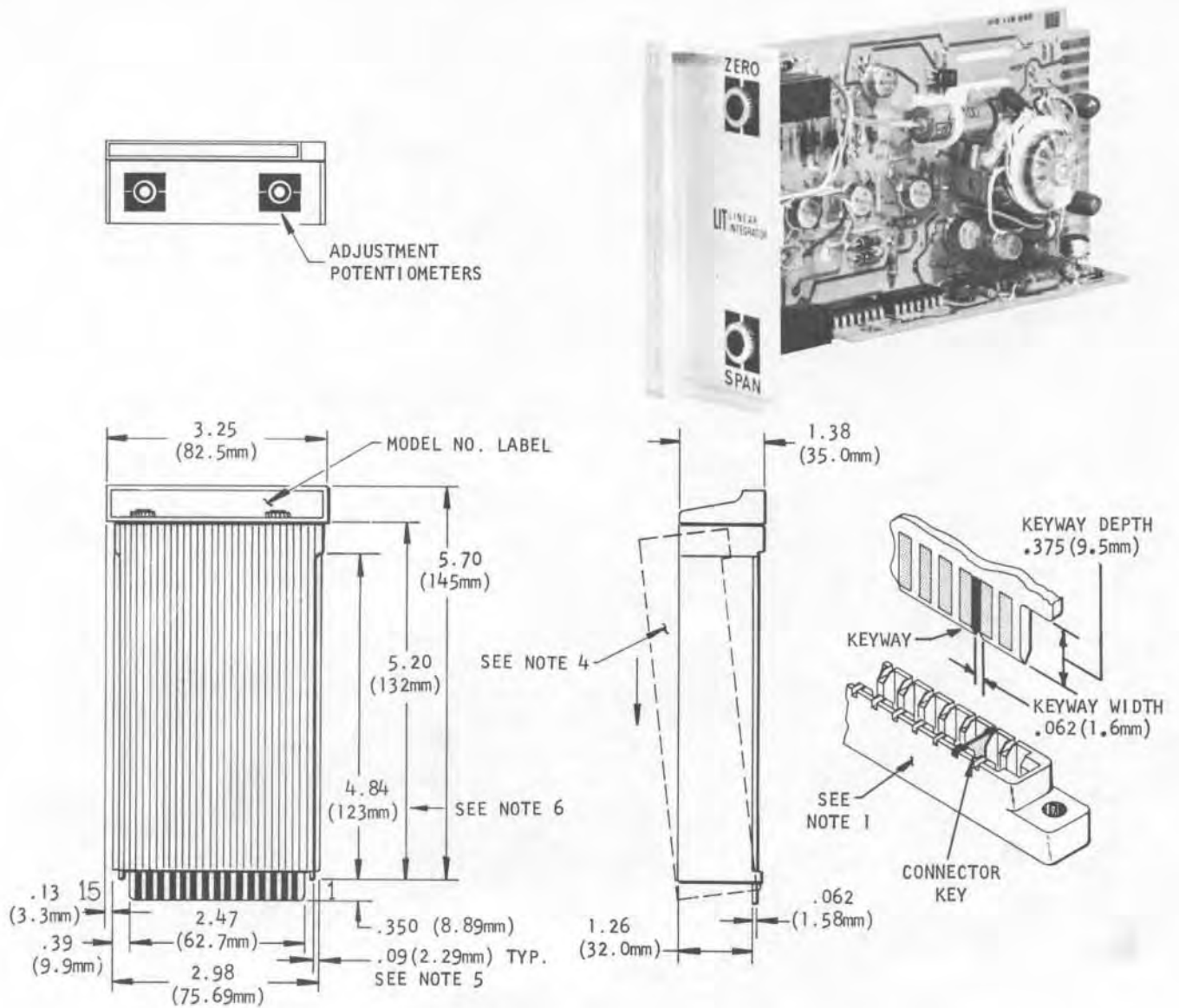

## NOTES:

1. Connectors used must have contacts on .156 (3,96mm) centers, with contacts for both surfaces of board (recommended type: Viking part no. 2VK155/1-2).
2. Maximum card insertion depth in connector is .350 (8,89mm).
3. Minimum width of connector insertion slot is 2.470 (62,70mm).
4. Removable plastic safety cover, 2.800 (71,12mm) wide. To remove safety cover, spread forward locking feet and lift front end approximately 1/4 inch; then slide cover to rear to disengage from card. **CAUTION** - DO NOT LIFT FRONT HIGHER THAN 1/4" OR TABS AT CONTACT END WILL BREAK.
5. Maximum card edge-guide insertion depth is .09 (2,29mm). Guides must be non-conductive.
6. Card edge-guides cannot extend beyond here.
7. Card extender part no. 350-513-00 is available for testing transmitter while in operating position

Figure 2-2. Outline and Installation

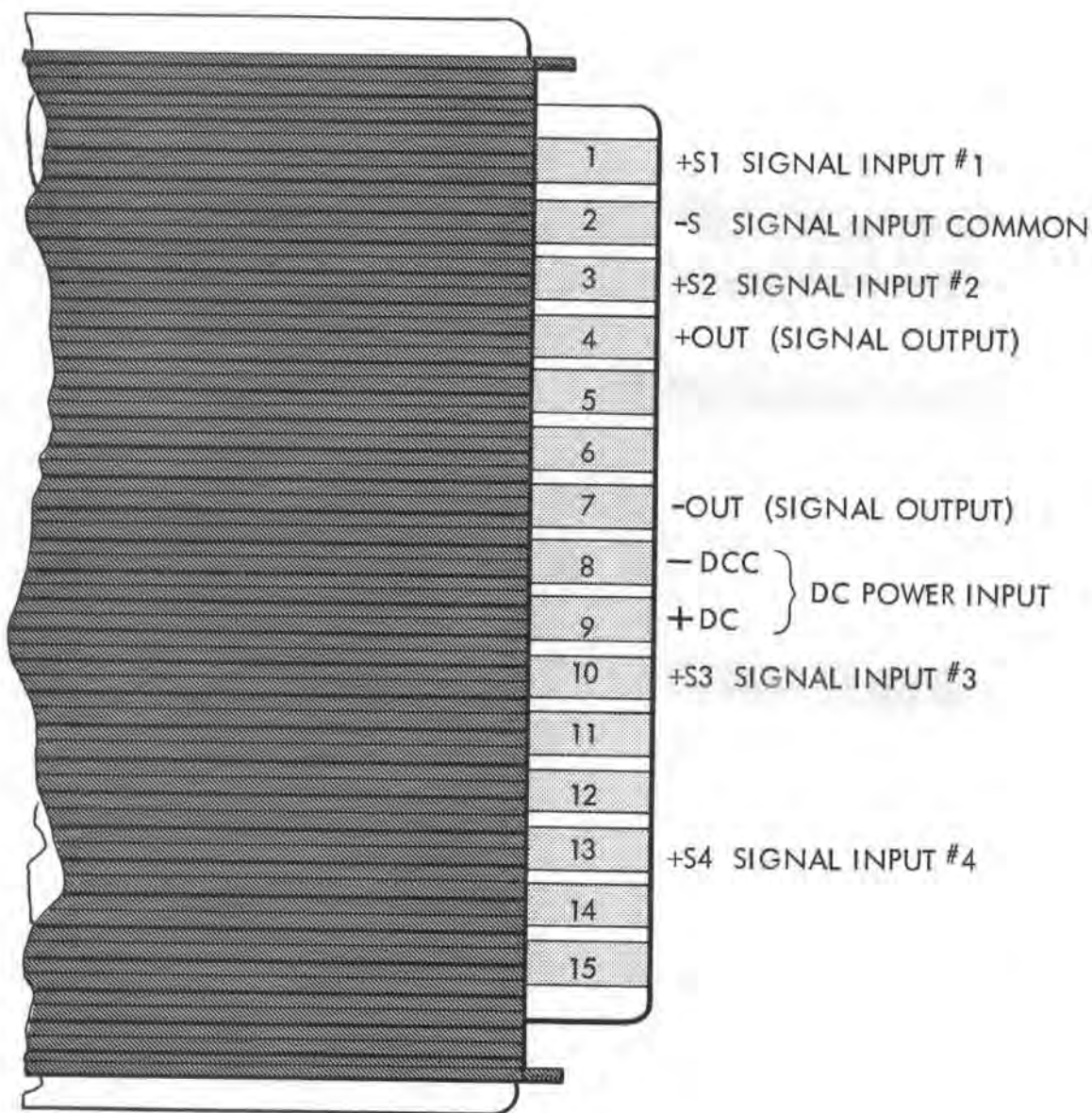

Figure 2-3. Electrical Connections For Plug-In Units

#### 3.1 OPERATING PROCEDURE

Once calibrated and installed, the unit may be operated unattended. The only controls on the outside of the unit are the SPAN and ZERO potentiometers which, after initial adjustment, need no further attention. There are no indicators on the unit. Because the circuit uses highly reliable solid-state components with no moving parts, the unit should operate virtually maintenance-free for a long period of time. However, if a malfunction should occur, refer to Section 5 for maintenance information.

A unit may become warm during operation, especially where the ambient temperature is rather high. This is perfectly normal and should not be a cause for alarm unless a malfunction is also observed.

#### 4.1 INTRODUCTION

This section describes the theory of operation of the unit. The description of each circuit is presented in sufficient detail so troubleshooting, if required, can be carried out intelligently and rapidly.

#### 4.2 CIRCUIT DESCRIPTION

The schematic diagram of the unit is at the end of this manual. Refer to this diagram when reading the following paragraphs.

##### 4.2.1 Power-Inverter Circuit

In the plug-in unit the DC applied to the power inverter input is converted to a square wave of approximately 3 KHz by Q1, Q2, and the primaries of T1. Filter L1-C3 prevents the square wave signal from getting back into the external source. Diode CR3 provides reverse polarity input protection. The output from center-tapped secondary 8-10-13 is rectified by full-wave rectifier, CR10, CR11, CR12 and CR13, filtered by C8 and C9, regulated by zener diodes, CR7 and CR5 and coupled to circuit points A and B as the +12 and -12 volt outputs. The voltage output from secondary 16-17 is rectified by CR14 filtered by C10 and coupled to circuit point C as the +38 volt output.

##### 4.2.2 Description Of Input Amplitude Discriminator Circuit

Integrated circuits IC3 through IC6 and IC1 comprise the input amplitude discriminator circuit. Up to four signals can be compared simultaneously and either the highest or lowest signal, depending on the input selection (high or low), can be chosen for output amplification.

###### 4.2.2.1 Low Selector Input Circuit

Low selection is made when the "Low Select" CR4, CR6, CR8, and CR9 diodes and jumper J3 are installed. When low selection is made, -12 volts is applied through J3, R8 and R9 to the cathodes of the "Low Select" diodes. Input signals applied at +S1 through +S4 to the inverting inputs (pin 2) of IC3 through IC6 forward biases the "Low Select" diodes. Since IC3 through IC6 are connected as comparators and are in the feedback loop of IC1, the output of IC1 (pin 6) will be equal to the lowest signal applied at the inputs.

###### 4.2.2.2 High Selector Input Circuit

When high selection is made +12 volts is applied through J4, R8 and R9 to the anodes of the "High Select" diodes, CR44, CR66, CR88, and CR99. Input signal applied at the inverting inputs (pin 2) of IC3 through IC6 forward biases the four "High Select" diodes. Since IC1 through IC4 are connected as comparators and are in the feedback loop of IC1, the output of IC1 (pin 6) will be equal to the highest signal applied at the inputs.



**4.2.3      Description Of Operational Amplifier Circuit**

The input to the operational amplifier circuit is the output of the input amplitude discriminator circuit. This signal is summed with the voltage from the ZERO adjust circuit at the inverting input (pin 3) of IC2. The ZERO adjust circuit is connected across plus and minus 6.2 volts, regulated by CR1 and CR2 and divided by R3, R5 and the ZERO adjust potentiometer. Feedback for IC2 is supplied from the power amplifier through R25 and the SPAN potentiometer to the non-inverting input (pin 2). The amount of feedback to IC2 and hence the maximum output of the unit is determined by the setting of the SPAN potentiometer. Operational amplifier IC2 operates from +12 and -12 volts.

**4.2.4      Description Of Power Amplifier Circuit**

The power amplifier consists of transistors Q3, Q5 and associated components for current outputs, and emitter follower Q4 for voltage output. Transistors Q3, Q4 and Q5 operate from +38 volts.

## MAINTENANCE INFORMATION

## 5.1 INTRODUCTION

This section contains information on maintenance of the unit. General troubleshooting procedures are given, using conventional signal-tracing techniques. Precautions and special techniques used to replace components are also described.

## 5.2 PERIODIC MAINTENANCE

It is suggested that the calibration of the unit be checked approximately every 6 months as described in Section 2. No other periodic maintenance is required.

## 5.3 CORRECTIVE MAINTENANCE

The following paragraphs provide information on corrective maintenance of the unit. Corrective maintenance should be carried out only by qualified personnel who have read and thoroughly understand the description of circuit operation given in Section 4.

5.3.1 Disassembly

To troubleshoot the unit, it is first necessary to disassemble it so the circuit board is exposed. In all cases, disconnect input signal and turn off power input before disassembling unit.

5.3.1.1 Disassembly Of A Plug-In Unit

To remove the cover of a plug-in unit with a -PC housing, proceed as follows:

- a. Gently spread the forward locking feet and lift the front of the cover NO MORE THAN 1/4 INCH. Excessive force applied to the cover may break the rear retaining clips.
- b. With the front of the cover raised, slide the cover to the rear to disengage it from the plug-in card.

If it is desired to test a plug-in unit in the operating position, a circuit-board extender (Part No. 350-513-00) is required to bring the unit forward so the components on the circuit board are accessible for troubleshooting.

5.3.2 Troubleshooting

The schematic diagram(s) includes flagged numbers at various points in the circuit. Table 5-1 gives the voltages and waveforms at these points for specified input-signal conditions. The assembly drawing (immediately after the schematic diagram) shows the physical location of the parts on the circuit board. Bear in mind that the circuit board is protected with a moisture-resistance coating. Therefore, it may be necessary to use a needle-point probe and exert a fair amount of pressure to break through the coating when it is desired to observe the signal or voltage at a specified point. When connecting a probe to a component on the circuit board exercise care to make sure the probe does not short-circuit to an adjacent component. In general, troubleshooting is carried out by tracing the signal with an oscilloscope and referring to the schematic

## MAINTENANCE INFORMATION

diagram(s) to determine what component might be causing an observed abnormal indication. If the original symptom was a complete failure of the unit to operate, the most logical place to look for trouble is in the power converter. If the unit was producing an incorrect (but not zero) output, check the outputs from the power converter and, if these are normal, apply a standard input signal and trace the resulting signal through the unit.

### 5.3.3 Component Replacement Techniques And General Precautions

Replace all defective components with identical parts. Refer to the assembly drawing(s) for a list of replacement parts. The letter S and a number, all enclosed in a circle, appear after the description of certain parts in this list. The number indicates the number of spares recommended to be kept on hand for that part, per unit, for up to ten units of the same type. For more than ten units, a spares complement of 10% on the indicated parts should be used.

Most parts used in the unit are quite small and are located in a confined area. Therefore, small hand tools are a necessity when servicing the unit. The following is a summary of the general techniques and precautions that should be observed to prevent damage to components in the unit:

- a. Use a transformer-operated low-voltage soldering iron with a grounded tip and rated at not more than 50 watts. A temperature-controlled tip is desirable.
- b. Use extreme care when unsoldering the leads to any component. Do not keep the soldering iron on a point for more than a few seconds at a time. Use a suction-type solder-removing tool (solder sucker) as an aid in unsoldering transistors and integrated circuits. The protective coating on the unit may be removed with trichlorethane or equivalent. Be sure adequate ventilation is provided when using this or any other chemical.

#### NOTE

Unused connections on integrated circuits are left unsoldered to aid in removal. Refer to the assembly drawing(s) for more complete information.

- c. Do not excessively bend or twist the leads of small components; they break easily.
- d. Before removing a component, observe the lead dress. Be sure that the lead dress of the replacement is the same as that of the original.

### MAINTENANCE INFORMATION

- e. Remove all flux from soldered joints with trichlorethane or equivalent.

#### NOTE

Units that were calibrated at the factory to customer's specifications have protective caps over the SPAN and ZERO potentiometers. These caps must be removed so the unit can be recalibrated. LIFT, DO NOT TWIST the caps off, using a screwdriver tip as a prying tool. Snap the caps back in place, WITHOUT TWISTING, when recalibration has been completed.

- f. Test the unit for proper operation, and, if necessary, recalibrate by the procedure given in Section 2. When the performance of the unit is known to be satisfactory, apply clear acrylic to reseal the unit where required.
- g. Check that all leads are clear of the board edge before reinstalling the board into its case.

TABLE 5-1 - WAVE FORMS & VOLTAGES

TEST POINT				
1				
2				
3				
4				
TEST POINT	WAVE FORM	24 VDC	45 VDC	65 VDC
5		48V	90V	130V

\* LOW VALUE OF AMPLITUDE CORRESPONDS TO "LOW" VALUE OF INPUT RANGE AND HIGH VALUE CORRESPONDS TO FULL SCALE VALUE OF INPUT RANGE.

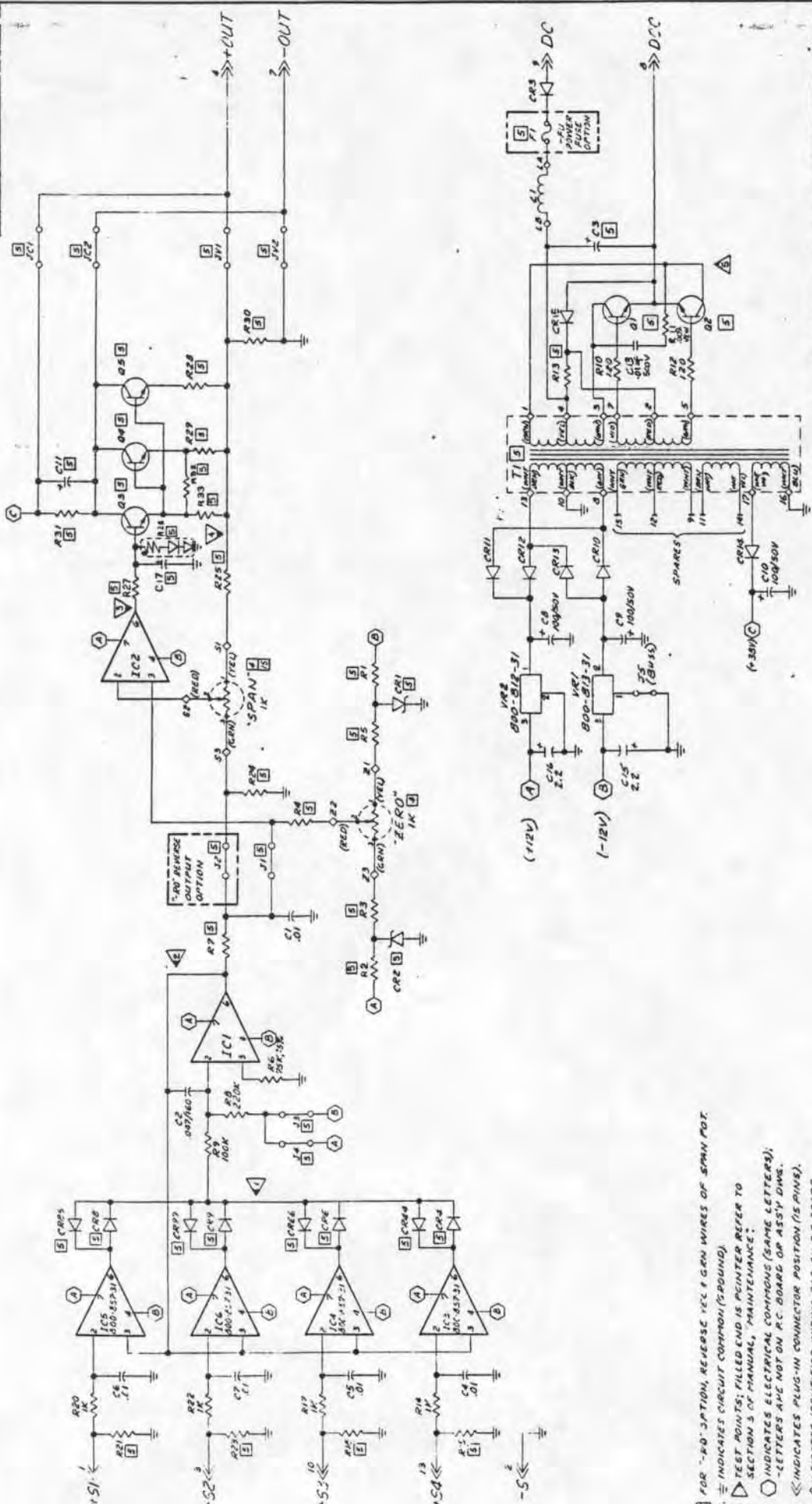

SCHEMATIC <b>ADM</b> (DC POWERED)	
SEE LIST OF MATERIALS FOR PART NUMBERS	
SEE LIST OF MATERIALS FOR VALUE AND/OR PART NUMBER.	
ALL POTENTIOMETERS INCREASE C.M. FROM 1 TO 3.	
ALL INTD. CPTS. ARE M.I.I. PIN 800-852-31; DIODES ARE M.I.I.	
PIN 800-4MB-11; RESISTORS ARE CARB COMP. M.M.I. OR.	
RESISTANCE IN OHMS; CAPACITANCE IN MICROFARADS.	
UNLESS OTHERWISE SPECIFIED	
164-451-001	

- 1. FOR "-R0" OPTION, REVERSE YEL & GRN WIRES OF SPAN POT.
- 2. ≡ INDICATES CIRCUIT COMMON (GROUND).
- 3. ▽ TEST POINTS; FILLED END IS POINTER REFER TO SECTION 3 OF MANUAL, MAINTENANCE.
- 4. ○ INDICATES ELECTRICAL COMMONS (SAME LETTERS); - LETTERS ARE NOT ON P.C. BOARD OR ASSY. DWS.
- 5. ◀◀ INDICATES PLUG-IN CONNECTOR POSITION (IS PINS).
- 6. ○ INDICATES IDENTIFIED WIRING PAD ON P.C. BOARD.
- 7. SEE LIST OF MATERIALS FOR VALUE AND/OR PART NUMBER.
- 8. ITEMS NOT MOUNTED ON P.C. BOARD.
- 9. ALL POTENTIOMETERS INCREASE C.M. FROM 1 TO 3.
- 10. ALL INTD. CPTS. ARE M.I.I. PIN 800-852-31; DIODES ARE M.I.I. PIN 800-4MB-11; RESISTORS ARE CARB COMP. M.M.I. OR.
- 11. RESISTANCE IN OHMS; CAPACITANCE IN MICROFARADS.

- 5 CR44 IS CR4 IN REVERSE; CR6 IS CR66 IN REVERSE; CR88 IS CR8 IN REVERSE; CR99 IS CR9 IN REVERSE.
  - 4. ALL JUMPERS ARE 22 AWG BUSS, TEFLON SLEEVED AS REQ'D.
  - 3. SLEEVE LEADS OF C15, C16 & VR2.
  - 2. SLEEVE EMITTER OF VR1.
  - 1. ALL LEADS MUST BE SOLDERED TO PADS
- NOTE 5- UNLESS OTHERWISE SPECIFIED:

DASH NO.		NEXT ASSEMBLY	
FINISH		TOL. UNLESS NOTED	
CUSTR.		PROJ. NO.	
SCALE 2:1		DO NOT SCALE DRAWING	
JOB NO. 164		MANUFACTURER	
164-551-00K		REFERENCE DESIGNATION	

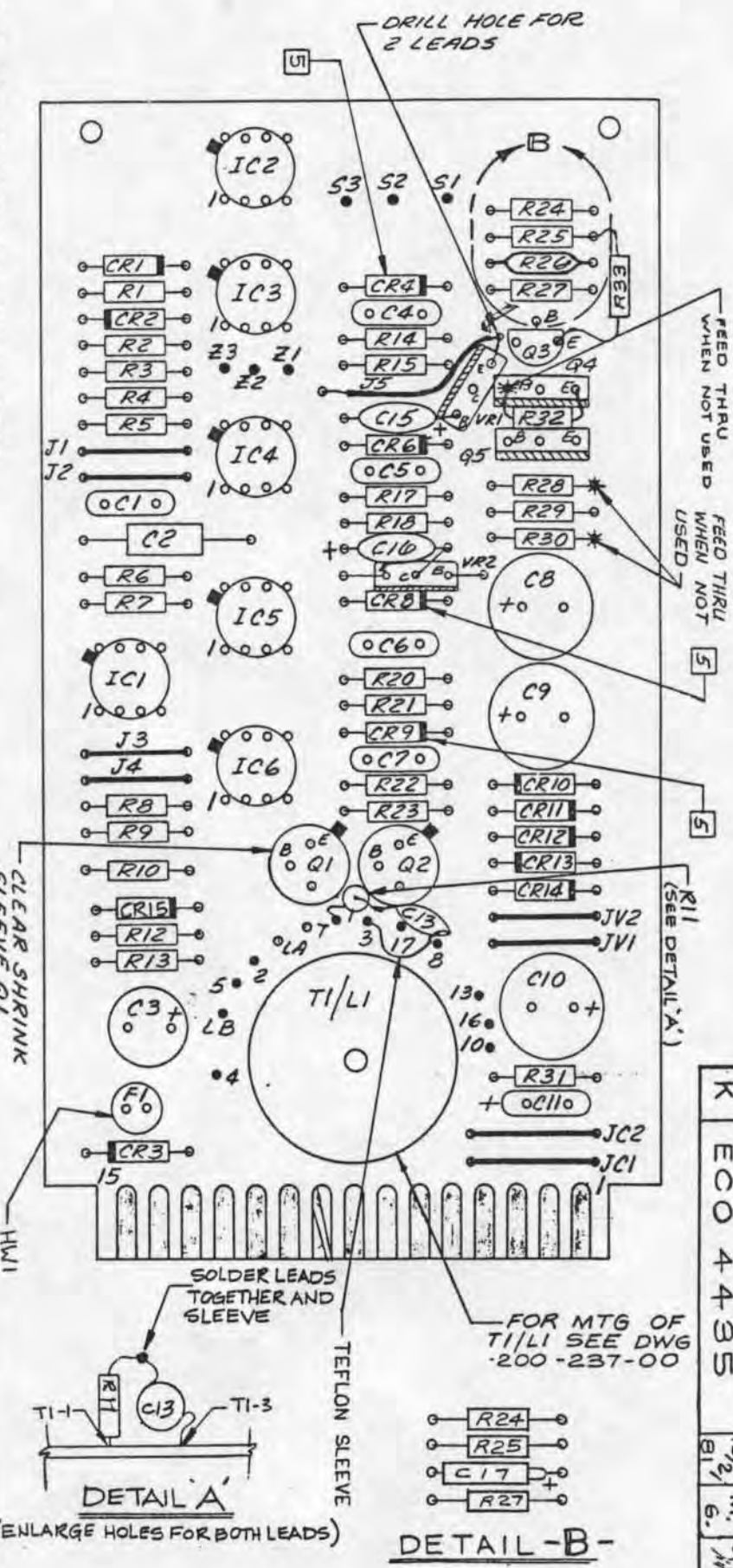

DETAIL A  
(ENLARGE HOLES FOR BOTH LEADS)

DETAIL B-

REV.	DESCRIPTION	DATE	BY	APPROV.
K	ECO 4435	10/21/61	M. J. K.	

# RETURN PROCEDURES

## To return equipment to Moore Industries for repair, follow these four steps:

1. Call Moore Industries and request a Returned Material Authorization (RMA) number.

### Warranty Repair –

If you are unsure if your unit is still under warranty, we can use the unit's serial number to verify the warranty status for you over the phone. Be sure to include the RMA number on all documentation.

### Non-Warranty Repair –

If your unit is out of warranty, be prepared to give us a Purchase Order number when you call. In most cases, we will be able to quote you the repair costs at that time. The repair price you are quoted will be a "Not To Exceed" price, which means that the actual repair costs may be less than the quote. Be sure to include the RMA number on all documentation.

2. Provide us with the following documentation:
  - a) A note listing the symptoms that indicate the unit needs repair
  - b) Complete shipping information for return of the equipment after repair
  - c) The name and phone number of the person to contact if questions arise at the factory
3. Use sufficient packing material and carefully pack the equipment in a sturdy shipping container.
4. Ship the equipment to the Moore Industries location nearest you.

The returned equipment will be inspected and tested at the factory. A Moore Industries representative will contact the person designated on your documentation if more information is needed. The repaired equipment, or its replacement, will be returned to you in accordance with the shipping instructions furnished in your documentation.

### WARRANTY DISCLAIMER

THE COMPANY MAKES NO EXPRESS, IMPLIED OR STATUTORY WARRANTIES (INCLUDING ANY WARRANTY OF MERCHANTABILITY OR OF FITNESS FOR A PARTICULAR PURPOSE) WITH RESPECT TO ANY GOODS OR SERVICES SOLD BY THE COMPANY. THE COMPANY DISCLAIMS ALL WARRANTIES ARISING FROM ANY COURSE OF DEALING OR TRADE USAGE, AND ANY BUYER OF GOODS OR SERVICES FROM THE COMPANY ACKNOWLEDGES THAT THERE ARE NO WARRANTIES IMPLIED BY CUSTOM OR USAGE IN THE TRADE OF THE BUYER AND OF THE COMPANY, AND THAT ANY PRIOR DEALINGS OF THE BUYER WITH THE COMPANY DO NOT IMPLY THAT THE COMPANY WARRANTS THE GOODS OR SERVICES IN ANY WAY.

ANY BUYER OF GOODS OR SERVICES FROM THE COMPANY AGREES WITH THE COMPANY THAT THE SOLE AND EXCLUSIVE REMEDIES FOR BREACH OF ANY WARRANTY CONCERNING THE GOODS OR SERVICES SHALL BE FOR THE COMPANY, AT ITS OPTION, TO REPAIR OR REPLACE THE GOODS OR SERVICES OR REFUND THE PURCHASE PRICE. THE COMPANY SHALL IN NO EVENT BE LIABLE FOR ANY CONSEQUENTIAL OR INCIDENTAL DAMAGES EVEN IF THE COMPANY FAILS IN ANY ATTEMPT TO REMEDY DEFECTS IN THE GOODS OR SERVICES, BUT IN SUCH CASE THE BUYER SHALL BE ENTITLED TO NO MORE THAN A REFUND OF ALL MONIES PAID TO THE COMPANY BY THE BUYER FOR PURCHASE OF THE GOODS OR SERVICES.

ANY CAUSE OF ACTION FOR BREACH OF ANY WARRANTY BY THE COMPANY SHALL BE BARRED UNLESS THE COMPANY RECEIVES FROM THE BUYER A WRITTEN NOTICE OF THE ALLEGED DEFECT OR BREACH WITHIN TEN DAYS FROM THE EARLIEST DATE ON WHICH THE BUYER COULD REASONABLY HAVE DISCOVERED THE ALLEGED DEFECT OR BREACH, AND NO ACTION FOR THE BREACH OF ANY WARRANTY SHALL BE COMMENCED BY THE BUYER ANY LATER THAN TWELVE MONTHS FROM THE EARLIEST DATE ON WHICH THE BUYER COULD REASONABLY HAVE DISCOVERED THE ALLEGED DEFECT OR BREACH.

### RETURN POLICY

For a period of thirty-six (36) months from the date of shipment, and under normal conditions of use and service, Moore Industries ("The Company") will at its option replace, repair or refund the purchase price for any of its manufactured products found, upon return to the Company (transportation charges prepaid and otherwise in accordance with the return procedures established by The Company), to be defective in material or workmanship. This policy extends to the original Buyer only and not to Buyer's customers or the users of Buyer's products, unless Buyer is an engineering contractor in which case the policy shall extend to Buyer's immediate customer only. This policy shall not apply if the product has been subject to alteration, misuse, accident, neglect or improper application, installation, or operation. THE COMPANY SHALL IN NO EVENT BE LIABLE FOR ANY INCIDENTAL OR CONSEQUENTIAL DAMAGES.



**WORLDWIDE • www.miinet.com**

United States • info@miinet.com  
Tel: (818) 894-7111 • FAX: (818) 891-2816

Australia • sales@mooreind.com.au  
Tel: (02) 8536-7200 • FAX: (02) 9525-7296

Belgium • info@mooreind.be  
Tel: 03/448.10.18 • FAX: 03/440.17.97

The Netherlands • sales@mooreind.nl  
Tel: (0)344-617971 • FAX: (0)344-615920

China • sales@mooreind.sh.cn  
Tel: 86-21-62491499 • FAX: 86-21-62490635

United Kingdom • sales@mooreind.com  
Tel: 01293 514488 • FAX: 01293 536852